

SECTION B-B

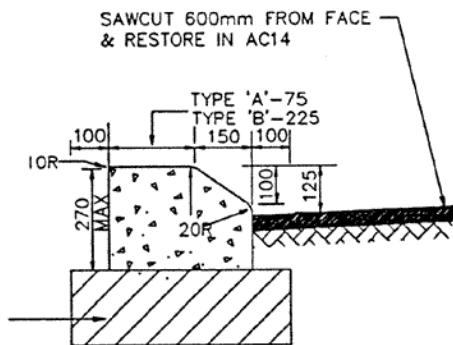

MOUNTABLE KERB

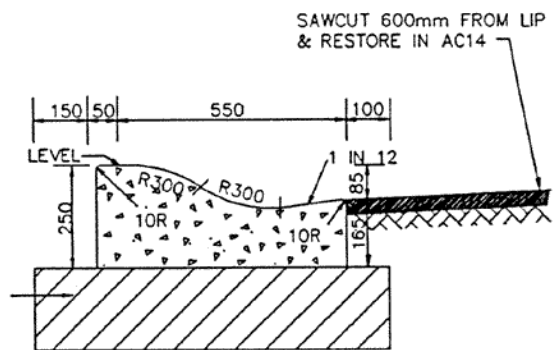

ROLL KERB

SPECIFICATIONS

1. SLAB THICKNESS AND REINFORCEMENT

RESIDENTIAL: 130mm F82 REO MESH TO 180mm F82 REO MESH.

COMMERCIAL: 180mm F92 REO MESH. (TO BE LOCATED WITH 40mm COVER FROM BOTTOM OF SLAB).

ALL CONCRETE F'c20 MPA.

2. BASE COURSE

CONSOLIDATED FINE CRUSHED ROCK TO COUNCILS SPECIFICATION

3. CONCRETE FINISH

A. ALL EDGES SHALL BE TOOL FINISHED WITH 12mm RAD 50mm WIDE EDGING TOOL.

B. GUTTER SHALL BE FINISHED WITH A STEEL TROWEL.

C. LAYBACK AND SLAB TO BE FINISHED WITH WOOD FLOAT.

4. EXPANSION JOINTS

EXPANSION JOINTS SHALL BE PLACED AT 6m INTERVALS

5. CONTRACTORS SHALL CONFORM TO THE COUNCILS "CONDITIONS" OF APPROVAL FOR CONSTRUCTION OF VEHICULAR CROSSING/CONCRETE FOOTPATHS AND TO LINE LEVEL AND GRADE FIXED BY COUNCIL

6. SITE OF WORK:

DURING AND ON COMPLETION OF WORK, ALL EXCAVATED MATERIAL FROM THE SITE SHALL BE REMOVED AND THE SITE KEPT IN A CLEAN, SAFE AND TIDY CONDITION TO THE SATISFACTION OF COUNCIL'S ENGINEER.

7. ALL PLAN DIMENSIONS ARE IN MILLIMETRES.

8. AC14mm ADJUSTMENT:

PROVIDE 600mm WIDE AC14 CORRECTION COARSE LAYER 50mm THICK AS SHOWN.

9. RESTORATION OF TURF

RESTORE TURF & TOPSOIL AT COMPLETION OF WORK UP TO 1M BEHIND BACK OF KERB (REMOVE UNWANTED MATERIAL).

APPROVED:

COUNCIL ENGINEER

DATE: 31/12/97



NORTH SYDNEY COUNCIL

STANDARD VEHICULAR
CROSSING, KERB &
GUTTER DETAIL

SCALE

NOT TO SCALE

DRAWING NO.

S101B