

All kerb ramps shall be constructed in Concrete
(unless otherwise directed)

CJ refers to construction joint.

Note: for ramps greater than 1520mm, maximum grade is 1 in 14

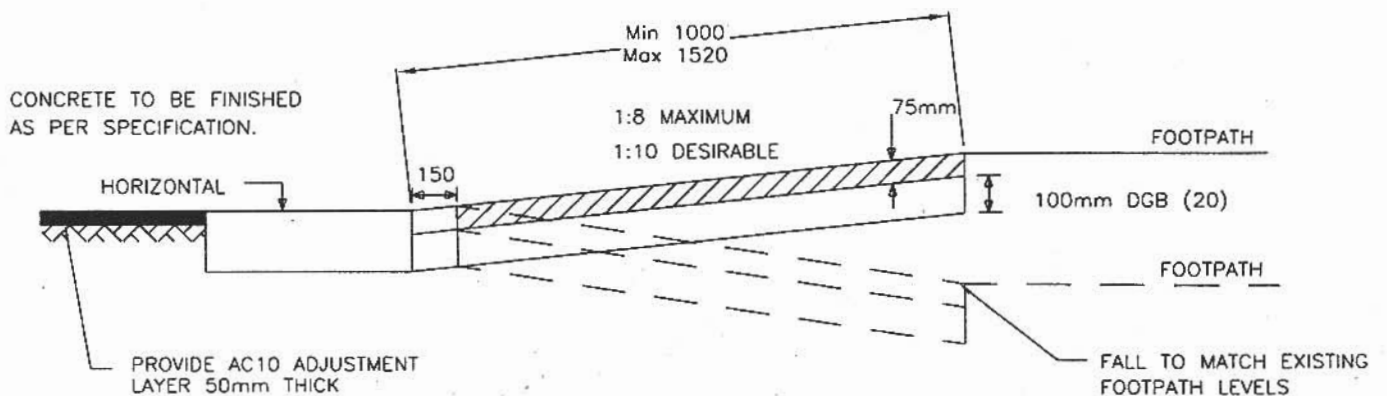
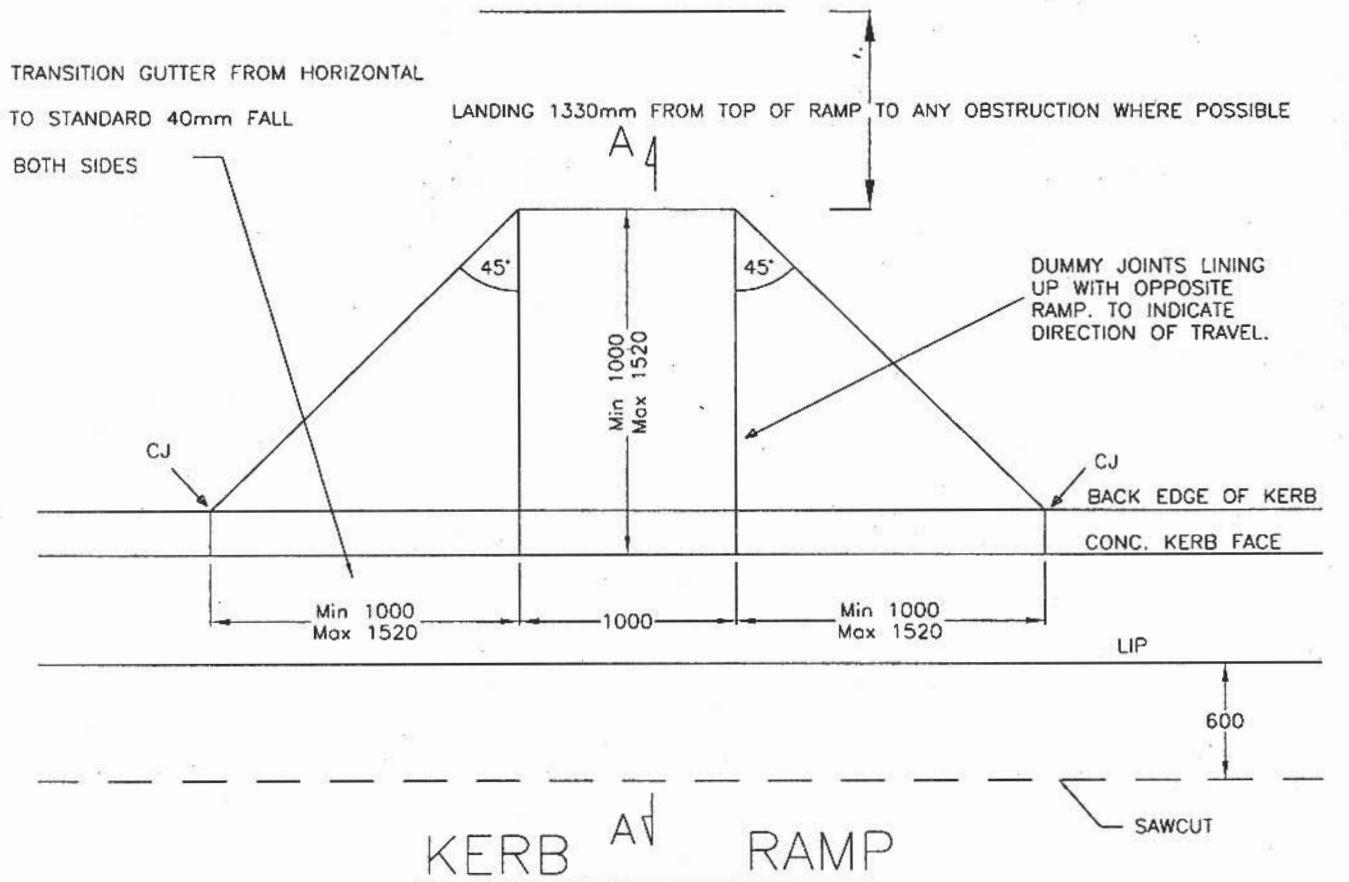

SECTION A-A

* ALL DIMENSION ARE IN MILLIMETERS

APPROVED:		NORTH SYDNEY COUNCIL	SCALE
COUNCIL ENGINEER		STANDARD KERB RAMP	NOT TO SCALE
DATE: 01/05/04			DRAWING NO. S105